

ADJUSTMENT OF THE GN 1300 SERIES 110 VOLT SYSTEM

The adjustment wheels on the controller should be reset so the arrows match the diagram below and perform the fine adjustments as shown.

With the power switch turned off and the unit unplugged, make the following initial adjustments

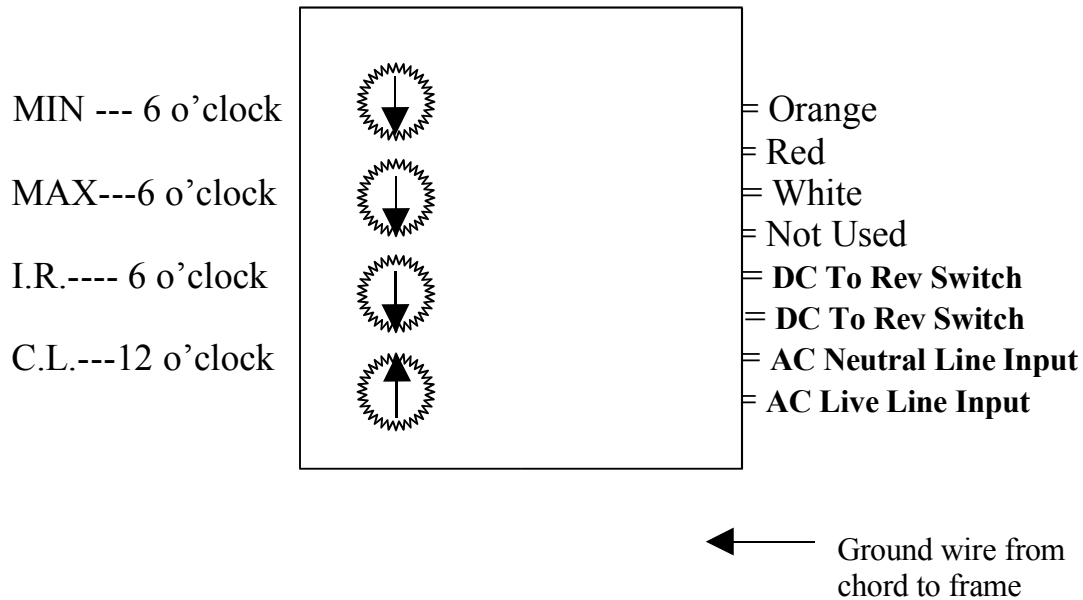

1. Turn the speed control dial to the slowest setting (full counter clockwise).

NOTE: The following is to be done with the unit plugged in and running so please use extreme caution. Use a non-metallic tool such as a Popsicle stick or a plastic knife to make adjustments.

2. Plug the unit in and turn on the key switch.
3. Turn the MIN control clockwise until a slight rotation of the motor is obtained.
4. Turn the IR slowly clockwise until a surging of the motor is noted. Now turn the IR counterclockwise until the surging stops.

Settings are now complete and the unit is ready for use. When the power is turned on, the motor will start to run in about 6 seconds. This time lag is normal and varies with the speed selector dial position at startup.